



**COLUMNA MEDICA BAJA POLAND**  
**POLISH CROSS-COUNTRY CUP / RAJDOWY PUCHAR POLSKI SAMOCHODÓW TERENOWYCH**  
**RPPST**  
**BULLETIN NO 4 / KOMUNIKAT NR 4**

---

Date/Data:	<b>03.09.2022</b>	Time/Czas:	<b>17:20</b>
Subject/Temat:	<b>Bulletin No. 4 / Komunikat Nr 4</b>	Doc. No./Dok. Nr.:	<b>1.4</b>
From/Od:	<b>Clerk of the Course / Dyrektora Zawodów</b>	Pages / Liczba stron:	<b>1+1</b>
To/Do:	<b>All competitors / Crew members</b> <b>Wszystkich zawodników / Członków załóg</b>	Att./Zał.:	<b>1</b>



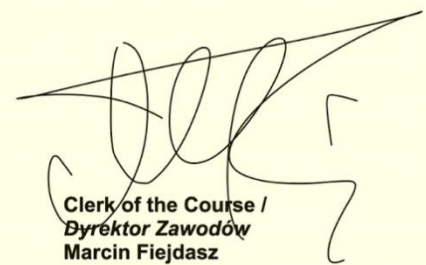

---

Due to the accident of car No 200 and Fire on the stage CoC has decided to shorten the SS3. The new Flying Finish is on Kilometer 64,25 = beginning of neutralization and Refueling Zone no 4. The passage from this point to service park TC3A is in the attached appendix 1.

The time allowed to TC3A is 5 minutes.

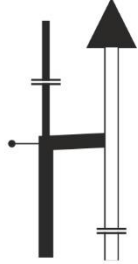

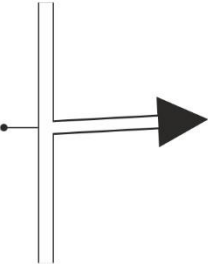
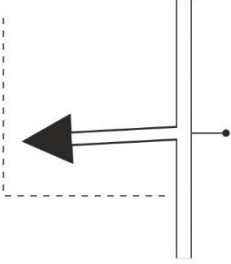
**Clerk of the Course /  
Dyrektor Zawodów  
Marcin Fiejdasz**

1	STOP SS3 -> TC 3A SERVICE	1,56 km
0,00		
0,00		
1,01		
1,01		
1,56		 TC-2A/3A  <div data-bbox="1050 1084 1184 1137" style="border: 1px solid black; padding: 2px;">                     N-53°27.318'                      E-15°46.484'                 </div>
0,55		